

Винты DIN 915 установочный цапфа внутренний шестигранник
Покрытие - фосфатирование

DIN 915

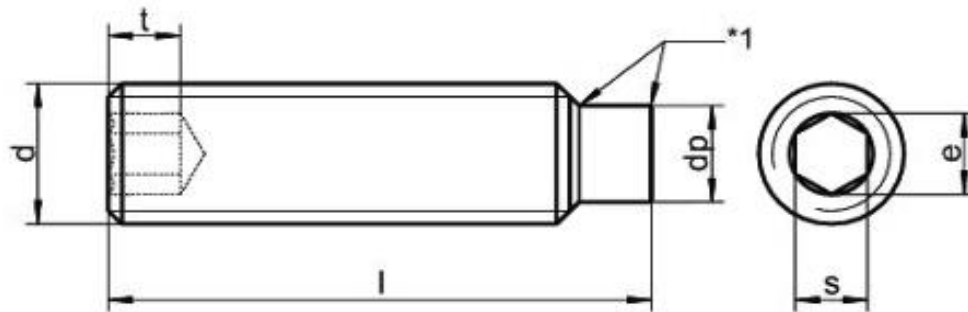

d	M 2	M 2,5	M 3	M 4	M 5	M 6	M 8
t	0,8/1,7	1,2/2,0	1,2/2,0	1,5/2,5	2,0/3,0	2,0/3,5	3,0/5,0
dp	1,0	1,5	2,0	2,5	3,5	4,0	5,5
e	1,003	1,427	1,730	2,300	2,870	3,440	4,580
s	0,9	1,3	1,5	2	2,5	3	4
d	M 10	M 12	M 14	M 16	M 20	M 24	
t	4,0/6,0	4,8/8,0		6,4/10,0	8,0/12,0		
dp	7,0	8,5	10,0	12,0	15,0	18,0	
e	5,720	6,860		9,150	11,430		
s	5	6	6	8	10	12	